

Model No.: XT25BG60-04  
 Product Line: Tymphany

Rev: 1  
 Last Update: 2017-05-24 09:25:54

## Product Description

This member of the XT tweeter family utilizes two Tymphany technologies to deliver exceptional sound quality: the ring radiator patent, and the central waveguide patent. This model features a 4 ohm 25 mm voice coil, mounted in a ferrite magnet motor. The tweeter also features a rear chamber to create extended low frequency response. The faceplate features recessed mounting holes which minimizes reflections off of mounting screws.



## Mechanical Drawing

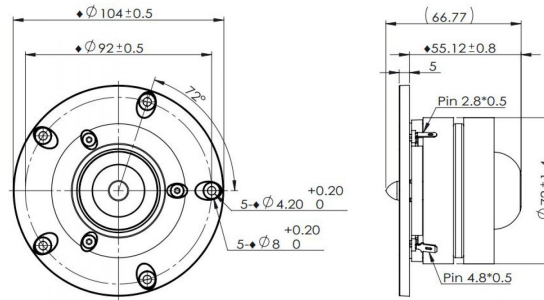

## Specifications

DC Resistance	Revc	Ohms	2.99	5.0%	Energy Bandwidth Product	EBP	(1/Qes)*fs	
Minimum Impedance	Zmin	Ohms	3.44	7.5%	Moving Mass	Mms	g	0.4
Voice Coil Inductance	Le	mH	0.01		Suspension Compliance	Cms	um/N	203.4
Resonant Frequency	Fs	Hz	589.1	15%	Effective Cone diameter	D	cm	3.24
Mechanical Q Factor	Qms		1.31		Effective Piston Area	Sd	cm <sup>2</sup>	8.2
Electrical Q Factor	Qes	0.43			Effective Volume	Vas	L	0.02
Total Q Factor	Qts	0.32			Motor Force Factor	BL	Tm	3.07
Ratio Fs/Qts	F	Fs/Qts	1840.94		Motor Efficiency Factor	β	(T*M <sup>2</sup> )/Ohms	3.2
Half Space Sensitivity @2.83V	db@2.83V/1M	dB	92.26	+/- 1.0db	Voice coil former Material	VCfm		ASV
Half Space Sensitivity @1W/1M	db@1W/1M	dB	88.6	+/- 1.0db	Voice coil inner diameter	VCd	mm	25.76
Gap Height	Gh	mm	2		Rated Noise Power	P	W	100
Maximum Linear Excursion	Xmax	mm	0.1		Test Spectrum Bandwidth		500Hz - 20kHz	
Ferrofluid Type	FF				Driver Size	Inch	25 mm	
Driver Mass	Kg	0.78						

## Frequency and Impedance Response

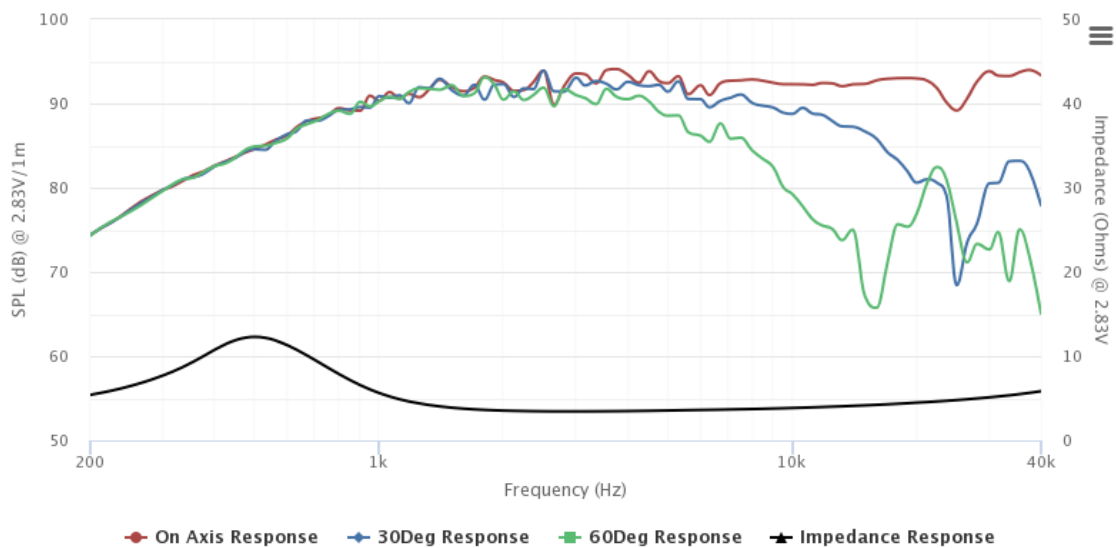

Highcharts.com