

# ICEpower300A2

Two Channel 300W ICEpower Amplifier  
Version 1.0

# 1. Contents

1.	Contents.....	1
2.	General Description.....	3
2.1	Key Specifications.....	3
3.	Release Notes .....	4
4.	Getting Started.....	5
5.	Block Diagram.....	5
6.	Connectors .....	6
6.1	P1: Power Rail Supply Connector .....	6
6.2	P6: Auxiliary Supply Connector.....	6
6.4	P7: Basic+ Control Connector.....	7
6.5	P3: Audio Input Connector .....	7
6.6	P4: Channel 1 Loudspeaker Output Connector .....	7
6.7	P5: Channel 2 Loudspeaker Output Connector .....	7
7.	Absolute Maximum Rating.....	8
7.1	Power Rail Supply Section .....	8
7.2	Auxiliary Supply Section .....	8
7.3	Control pin section P7.....	8
7.4	Amplifier Signal Input Section.....	8
7.5	Output Section .....	8
8.	Electrical Specifications.....	9
8.1	General .....	9
8.2	Power specification.....	9
8.3	Audio .....	10
8.4	Control and Status .....	12
8.5	Timing .....	12
9.	Mechanical Specification .....	13
9.1	Dimensions .....	13
9.2	3D-View.....	13
9.3	Mounting holes .....	14
9.4	Environmental Specifications .....	16
10.	Typical Performance Characteristics SE.....	17
10.1	Frequency Response.....	17
10.2	Total Harmonic Distortion + Noise.....	18
10.3	Idle Noise.....	18
10.4	Intermodulation Distortion .....	19
10.5	Crosstalk.....	19
10.6	Output Impedance .....	19
10.7	Damping Factor .....	20
10.8	Output Power vs. Rail Voltage supplies.....	20
10.9	Power Efficiency.....	21

10.10	Dissipated Power.....	21
11.	Typical Performance Characteristics BTL.....	22
11.1	Frequency Response.....	22
11.2	Total Harmonic Distortion + Noise.....	22
11.3	Idle Noise and Low Power spectrum.....	23
11.4	Intermodulation Distortion .....	23
11.5	Output Impedance .....	24
11.6	Damping Factor .....	24
12.	Functional Description .....	25
12.1	Audio Input .....	25
12.2	Loudspeaker Outputs.....	25
12.3	Power Supply Input.....	26
12.4	Basic Control and Status .....	26
13.	Interface Schematics.....	29
13.1	Audio Input .....	29
13.2	Control Input.....	30
13.3	Status Output.....	30
14.	Integration Guidelines .....	31
14.1	Grounding Scheme.....	31
14.2	EMC Management .....	32
15.	Safety and EMC Standards.....	32
16.	ESD Warning.....	33
17.	Ordering, Packaging and Storage.....	33
17.1	Ordering Information.....	33
17.2	Shipping Dimensions and Weight .....	33
17.3	Storage Conditions .....	33
18.	Legal Notes.....	34
19.	Contact .....	34

## 2. General Description

ICEpower300A2 is designed for outstanding audio quality in a compact size. The 300A2 incorporates the latest in state of the art custom ICEpower patented ICEedge Chipset technology, enabling superior sound quality with an ultra-low noise floor, of typical 22  $\mu$ V for a SNR ratio of 123.5 dB. It is an efficient two/one-channel audio power amplifier intended for driving two 4  $\Omega$  loudspeakers or one 8  $\Omega$  speaker in BTL mode.

The ICEpower300A2 provides comprehensive protection and monitoring functions with an easy-to-use control interface. Additionally, dedicated monitor outputs for loudspeaker connector output voltage enables real time protection system of the loudspeaker.

ICEpower300A2 is designed for high continuous output power, making it ideal for applications requiring sustained output power not only for home hi-fi, but also for demanding studio monitor and high performance amplifier for PRO audio speakers as well. The integrated aluminum heatsink enables easy extended heat transfer to external heatsink so improved long term output power can be achieved

The ICEpower300A2 is design to comply with EMC and safety enabling fast design-in and minimum time to market.

### Features

---

Can be configured as a two channel SE amplifier or a single channel BTL amplifier

---

Designed for flexible mounting and, if needed, easy mechanical interface to external heatsink for even higher continuous power capability

---

Designed as hanger module for both 1500S-57V and 1200AS1/2

---

Thermal, over-current and over- and under- voltage rail protection

---

Suitable for 1U products

---

Fully differential audio inputs

---

Amplifier Disable function

---

Clip detect signals for both channels

---

Real time voltage monitor output for both channels

---

### 2.1 Key Specifications

- 2 channel 300 W @ 1 % THD+N, 20 Hz – 20 kHz, 4  $\Omega$  or  
1 channel 600 W @ 1 % THD+N, 20 Hz – 20 kHz, 8  $\Omega$
- 123.5 dB(A) dynamic range SE
- 127 dB(A) dynamic range BTL
- THD+N = 0.0008 % @ 10 W (4  $\Omega$ , 100 Hz) SE
- THD+N = 0.0009 % @ 50 W (4  $\Omega$ , 100 Hz) SE
- Load independent frequency response
- Very low THD+N in the entire audio band
- Very low IM distortion
- <25uVrms A-weighted idle noise SE
- <35uVrms A-weighted idle noise BTL
- Dimensions (L x W x H): 100 x 60 x 35 mm, (3.93 x 2.36 x 1.38 inch)

### 3. Release Notes

<b>Data Sheet Version</b>	<b>Date</b>	<b>Revised by</b>	<b>Description</b>
1.0	2021-03-02	JAP/LBH/ASP	Release version

## 4. Getting Started

ICEpower300A2 is a fully self-contained amplifier module and requires no interaction nor control to operate.

For first time use, please connect an audio source to the analog input and loudspeakers to the loudspeaker output connectors before applying power to the power rail supply connectors. ICEpower300A2 will start operating a few seconds after all supply voltages are applied.

The ICEpower300A2 is a two-channel single ended output Class D audio amplifier utilizing ICEpower patented technology. Each channel comprises a high impedance fully balanced input buffer for high suppression of hum and noise in a multi-channel application. The two-channel amplifier module can easily be bridged creating a single channel of higher output power by connecting the two balanced inputs with inverted polarity and activating BTLselect by pulling it high.

Important: The module should only be supplied by either DVDD/DVSS or VDD/VSS.

## 5. Block Diagram

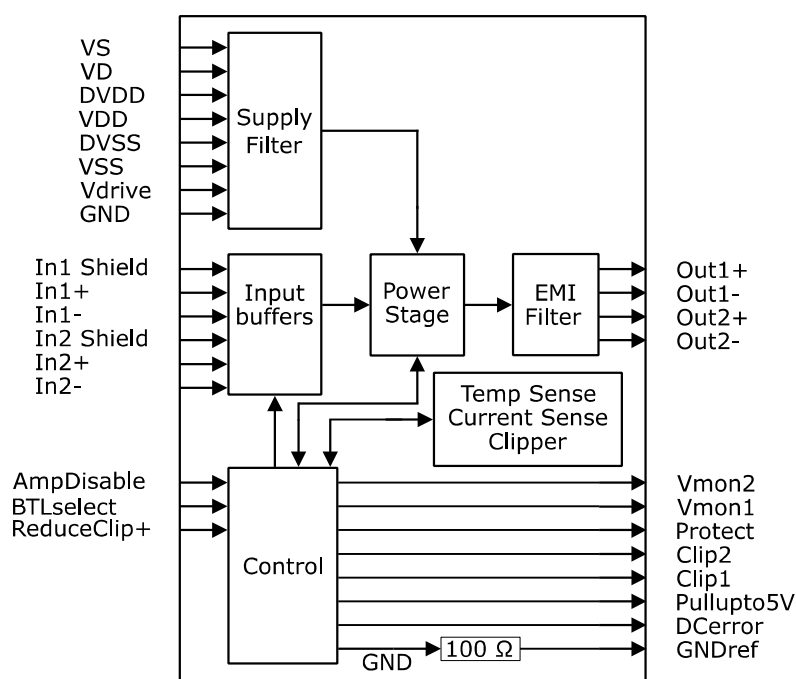

Figure 1: ICEpower300A2 block diagram

## 6. Connectors

The ICEpower300A2 module comes with industry standard connectors selected for long-term reliability.

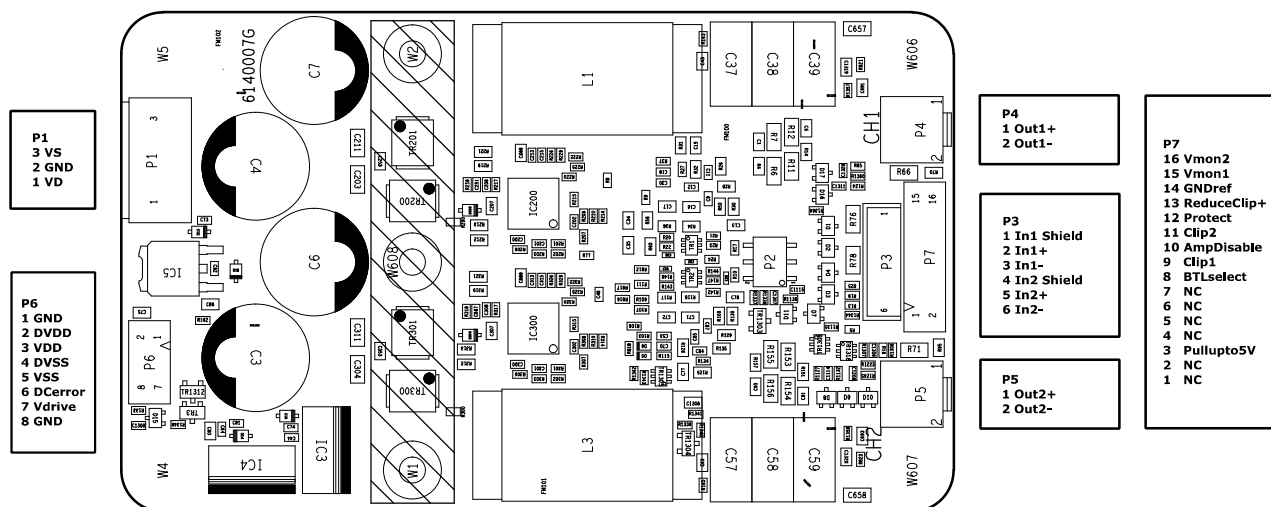

Figure 2: ICEpower300A2 connector overview

### 6.1 P1: Power Rail Supply Connector

Type: JST, B03P-NV (LF)(SN)				
PIN	Function	Description	Type	Reference
1	VD	Positive amplifier DC rail supply	Power input	GND
2	GND	Ground	Power GND	
3	VS	Negative amplifier DC rail supply	Power input	GND

Table 1: Power rail connector

### 6.2 P6: Auxiliary Supply Connector

Type: JST, B8B-PHDSS (LF)(SN)				
PIN	Function	Description	Type	Reference
1	GND	Ground	GND	
2	DVDD	Positive supply for control circuit	Input	GND
3	VDD	Positive supply for analog circuit	Input	GND
4	DVSS	Negative supply for control circuit	Input	GND
5	VSS	Negative supply for analog circuit	Input	GND
6	DCerror	DC error for the supply to shut down	Status output, open drain, active low	GND
7	Vdrive	Vdrive voltage for the power stage	Input	VS
8	GND	Ground	GND	

Table 2: Auxiliary Supply connector

The module should only be supplied by either DVDD/DVSS or VDD/VSS

## 6.4 P7: Basic+ Control Connector

Type: JST, B16B-PHDSS (LF)(SN)				
PIN	Function	Description	Type	Reference
1	NC		NC	
2	NC			
3	Pullupto5V	Coupled to 5V via a 47k resistor	Output	GND
4	NC		NC	
5	NC		NC	
6	NC		NC	
7	NC		NC	
8	BTLselect	Select BTL mode, active high	Control input, active high	GND
9	Clip1	Voltage clip indicator, channel 1	Status output, open drain, active low	GND
10	AmpDisable	Disable amplifier (mute)	Control input, active high	GND
11	Clip2	Voltage clip indicator, channel 2	Status output, open drain, active low	GND
12	Protect	Protect signal	Status output, open drain, active low	GND
13	ReduceClip+	Reduce clip level	Control input, active high	GND
14	GNDref	Ground ref, (terminated through 100 $\Omega$ to GND)	GND	Resistor to GND
15	Vmon1	Voltage monitor, channel 1	Analog Output	GND
16	Vmon2	Voltage monitor, channel 2	Analog Output	GND

Table 3: Basic Control Connector

## 6.5 P3: Audio Input Connector

Type: JST, B6B-PH-K-S (LF)(SN)				
PIN	Function	Description	Type	Reference
1	In1 Shield	Analog audio input shield	Input	Resistor to GND
2	In1+	Non-Inverting analog audio input signal	Input	GND
3	In1-	Inverting analog audio input signal	Input	GND
4	In2 Shield	Analog audio input shield	Input	Resistor to GND
5	In2+	Non-Inverting analog audio input signal	Input	GND
6	In1-	Inverting analog audio input signal	Input	GND

Table 4: Audio Input connector

## 6.6 P4: Channel 1 Loudspeaker Output Connector

Type: JST, B2P-VH (LF)(SN)			
PIN	Function	Description	Type
1	Out1+	Amplifier output, channel 1	Audio power Output
2	Out1-	Amplifier GND output, channel 1 <sup>1)</sup>	Audio power Output

Table 5: Channel 1 Loudspeaker Output connector

<sup>1)</sup>Do not connect this to normal GND.

## 6.7 P5: Channel 2 Loudspeaker Output Connector

Type: JST, B2P-VH (LF)(SN)			
PIN	Function	Description	Type
1	Out2+	Amplifier output, channel 2	Audio power Output
2	Out2-	Amplifier GND output, channel 2 <sup>1)</sup>	Audio power Output

Table 6: Channel 2 Loudspeaker Output connector

<sup>1)</sup>Do not connect this to normal GND.



## 7. Absolute Maximum Rating

Absolute maximum ratings indicate limits beyond which damage may occur.

### 7.1 Power Rail Supply Section

Pin	Parameter	MIN	MAX	Unit
P1: 2,1	Positive amplifier DC rail supply	+35	+65	Vdc
P1: 2,3	Negative amplifier DC rail supply	-35	-65	Vdc

Table 7: Absolute maximum ratings, power supply section

### 7.2 Auxiliary Supply Section

Pin	Parameter	MIN	MAX	Unit
P6: 1,2	Positive analog control supply (DVDD)	+4.5	+5.5	Vdc
P6: 1,4	Negative analog control supply (DVSS)	-4.5	-5.5	Vdc
P6: 1,3	Positive analog supply (VDD)	7	17	Vdc
P6: 1,5	Negative analog supply (VSS)	-7	-17	Vdc
P6: 7 to P1: 1	Vdrive supply (referenced to VS)	+12	+17	Vdc

Table 8: Absolute maximum ratings, auxiliary supplies

### 7.3 Control pin section P7

Pin	Parameter	MIN	MAX	Unit
8 BTLselect	Voltage range on control pin	-0.3	+20	Vdc
10 AmpDisable	Voltage range on control pin	-0.3	+20	Vdc
13 ReduceClip+	Voltage range on control pin	0	5	Vdc

Table 9: Absolute maximum ratings, control pin section

### 7.4 Amplifier Signal Input Section

Pin	Parameter	Value	Unit
P3: 4, 5   4, 6 P3: 1, 2   1, 3	Maximum voltage range on audio input pins	$\pm 5$	V <sub>p</sub>

Table 10: Absolute maximum ratings, input section

### 7.5 Output Section

Pin	Parameter	Value	Unit
P4: (1+2), (3+4)	Minimum symmetrical amplifier load resistance SE	3.5	$\Omega$
	Minimum asymmetrical amplifier load resistance SE	$3 \leq \text{Ch1}, 8 \leq \text{Ch2}$	$\Omega$
P5: (1+2), (3+4)	Maximum current draw from amplifier output	20	A
	Maximum amplifier pure capacitive load	330	nF
P7: 3,9,11,12,15,16	Maximum current draw from basic control connector	20	mA

Table 11: Absolute maximum ratings, output section

## 8. Electrical Specifications

Unless otherwise specified:

- $f = 1 \text{ kHz}$ ,  $T_a = 25 \text{ }^\circ\text{C}$ ,  $R_L = 4\Omega$ ,  $V_D/V_S = \pm 57\text{V}$ ,  $V_{DD}/V_{SS} = \pm 12\text{V}$ ,  $V_{drive} = V_S + 12$ .
- Audio Precision AUX0025 passive class-D filter and AES17 20 kHz 7<sup>th</sup> order measurement filter.
- ICEpower300A2 mounted on standoffs horizontal on plain surface, no additional heatsink or fan.

### 8.1 General

Symbol	Parameter	Conditions	Min	Typ	Max	Unit
$f_{sw}$	Switching frequency	Idle	450	500	550	kHz
$f_{sw}$	Switching frequency range	Idle to full scale	150		560	kHz
	Vmon1, Vmon2 output voltage range	Idle to 1% THD+N Output power (49Vp@300W, 4 $\Omega$ )	0		$\pm 5$	V <sub>p</sub>
	Voltage monitor gain, speaker output to Vmon outputs			0.1		-
	Voltage monitor frequency response	$f = 20 \text{ Hz} - 20 \text{ kHz}$		$\pm 0.1$		dB
	Voltage monitor phase response	$f = 20 \text{ Hz} - 20 \text{ kHz}$		$\pm 0.15$		Deg
	Monitor output impedance			100		$\Omega$
	Monitor output impedance, ground sense wire			100		$\Omega$

Table 12: Electrical specifications

### 8.2 Power specification

Symbol	Parameter	Conditions	Min	Typ	Max	Unit
$V_D$	Normal operating DC supply voltage		+35	57	+60	V
$V_S$	Normal operating DC supply voltage		-60	-57	-35	V
VDD	Normal operating pos. analog supply		+11	+12	+14	V
VSS	Normal operating neg. analog supply		-14	-12	-11	V
Vdrive	Normal operating drive analog supply		$V_S + 12$	$V_S + 15$	$V_S + 17$	V
DVDD	Normal operating pos. analog supply		4.5	5	5.5	V
DVSS	Normal operating neg. analog supply		-4.5	-5	-5.5	V
$t_{Pmax}$	Duration of power burst at full power, one channel driven	$P_o = 300 \text{ W}$		340		S
$t_{Pmax}$	Duration of power burst at full power, both channels driven	$P_o = 2 \times 300 \text{ W}$		140		S
$P_{o-con}$	Continuous output power without thermal shutdown, one channel driven	THD+N < 1 %		120		W
$P_{o-con}$	Continuous combined output power without thermal shutdown, both channels driven <sup>1)</sup>	THD+N < 1 %		110		W
$I_q$	Idle current consumption	V <sub>D</sub> V <sub>S</sub> VDD VSS Vdrive DVDD DVSS		22 22 85 70 100 84 70		mA
$P_q$	Total idle power consumption			5.5		W

Idisabled	Disabled current consumption	VD		3	mA
		VS		3	
		VDD		30	
		VSS		13	
		Vdrive		10	
		DVDD		28	
		DVSS		12	
		Pdisabled	Disabled power consumption		
$\eta$	Module power efficiency both channels driven	Po = 2x300W, 4 $\Omega$		92	%
		Po = 2x200W, 4 $\Omega$		91	
		Po = 2x100W, 4 $\Omega$		88	
		Po = 2x50W, 4 $\Omega$		84	

Table 13: Power specifications

<sup>1)</sup>The continuous combined output power is the sum of the power of the driven channels. This available output power can be distributed evenly or asymmetrically across the channels.

## 8.3 Audio

Symbol	Parameter	Conditions	Min	Typ	Max	Unit
P <sub>o</sub>	Output power @ 1 % THD+N f = 1 kHz, 1ch drivens f = 1 kHz, 2ch driven	R <sub>L</sub> = 4 $\Omega$		325		W
				305		
P <sub>o</sub>	Output power @ 10 % THD+N f = 1 kHz, 2ch driven	R <sub>L</sub> = 4 $\Omega$		355		W
P <sub>o</sub>	Output power @ 1 % THD+N 20 Hz < f < 20 kHz, 1ch driven 20 Hz < f < 20 kHz, 2ch driven	R <sub>L</sub> = 4 $\Omega$		300		W
				280		
P <sub>o</sub>	Output power @ 1 % THD+N 20 Hz < f < 20 kHz, 1ch driven 20 Hz < f < 20 kHz, 2ch driven	R <sub>L</sub> = 4 $\Omega$ $\pm 58$ V (1200AS)		310		W
				290		
P <sub>o</sub>	Output power @ 1 % THD+N 20 Hz < f < 20 kHz, 1ch driven 20 Hz < f < 20 kHz, 2ch driven	R <sub>L</sub> = 8 $\Omega$		160		W
				145		
P <sub>o</sub>	Output power @ 1 % THD+N f = 1 kHz, 2ch driven Asymmetrical load	R <sub>L</sub> = 3 $\Omega$ + 8 $\Omega$		405		W
				150		
P <sub>o</sub>	Output power @ 1 % THD+N 20 Hz < f < 20 kHz, 2ch driven Asymmetrical load	R <sub>L</sub> = 3 $\Omega$ + 8 $\Omega$		380		W
				140		
P <sub>o_BTL</sub>	Output power BTL @ 1 % THD+N f = 1 kHz	R <sub>L</sub> = 8 $\Omega$		615		W
P <sub>o_BTL</sub>	Output power BTL @ 1 % THD+N 20 Hz < f < 20 kHz	R <sub>L</sub> = 8 $\Omega$		560		W
THD+N	THD+N in 4 $\Omega$ SE	f = 100 Hz, P <sub>o</sub> = 10 W		0.0008		%
THD+N	THD+N in 8 $\Omega$ BTL	f = 100 Hz, P <sub>o</sub> = 10 W		0.0006		%

N	Output referenced idle noise (SE) 20 Hz < f < 20 kHz	A-weighted Unweighted		22 30		$\mu\text{V}$
N	Output referenced idle noise (BTL) 20 Hz < f < 20 kHz	A-weighted Unweighted		32 45		$\mu\text{V}$
$A_v$	Nominal Voltage Gain (SE)	$f = 1 \text{ kHz}, P_o = 1 \text{ W}$		25.7		dB
$A_v$	Nominal Voltage Gain (BTL) <sup>1)</sup>	$f = 1 \text{ kHz}, P_o = 1 \text{ W}$		31.7		dB
f	Frequency response (SE) 20 Hz < f < 20 kHz	$R_L = 4 \Omega - \text{infinity } \Omega$ $f_{\text{ref}} = 1 \text{ kHz},$ $P_o = 1 \text{ W}$		+0.0 -0.5		dB
f	Frequency response (BTL) 20 Hz < f < 20 kHz	$R_L = 8 \Omega - \text{infinity } \Omega$ $f_{\text{ref}} = 1 \text{ kHz},$ $P_o = 1 \text{ W}$		+0.0 -0.5		dB
$f_{U\_SE}$	Upper bandwidth limit (-3 dB) (SE)	$R_L = 4 \Omega, P_o = 1 \text{ W}$		70		kHz
$f_{U\_BTL}$	Upper bandwidth limit (-3 dB) (BTL)	$R_L = 8 \Omega, P_o = 1 \text{ W}$		80		kHz
$f_L$	Lower bandwidth (-3dB)	$R_L = \text{all loads},$ $P_o = 10 \text{ W},$ no measurement filters		3		Hz
$f_{L\_power}$	Lower bandwidth at nominal power	$R_L = 4 \Omega,$ $P_o = 300 \text{ W},$ no measurement filters		20		Hz
$Z_{in\_signal}$	Input impedance, Signal IN+ and IN-	$f = 1 \text{ kHz}$		38		k $\Omega$
$Z_o$	Abs. output impedance	$f = 1 \text{ kHz}$		9		m $\Omega$
$R_L$	Load impedance range 2-channel mode, symmetrical loading		3.5	4	$\infty$	$\Omega$
$R_L$	Load impedance range 2-channel mode, assymetrical loading	Ch1 $\geq 3$ , CH2 $\geq 8$	3+8		$\infty$	$\Omega$
$R_L$	Load impedance range BTL mode		7	8	$\infty$	$\Omega$
$V_{O\_max\_SE}$	Maximum output voltage	$R_L = 4 \Omega$		51		Vp
$V_{O\_max\_BTL}$	Maximum output voltage	$R_L = 8 \Omega$		100		Vp
$C_{load}$	Capacitive load				330	nF
DNR	Dynamic range SE	A-weighted 300 W @ 4 $\Omega$		123.5		dB
DNR	Dynamic range BTL	A-weighted 600 W @ 8 $\Omega$		127		dB

Table 14: General audio specifications

<sup>1)</sup>With configuration shown in Figure 28

### 8.3.1 Asymmetrical Loading

It is also possible to load one channel with 3  $\Omega$  and the other channel with 8  $\Omega$ . This can be used to provide power to a low/midrange driver while still having enough power to drive a high frequency driver.

## 8.4 Control and Status

Symbol	Parameter	Conditions	Min	Typ	Max	Unit
V <sub>control</sub>	Control input voltage range	AmpDisable, BTL select	0		20	V
		Reduce Clip+	0		5	
V <sub>control_low</sub>	Control input low signal				0.8	V
V <sub>control_high</sub>	Control input high signal		3			V
Z <sub>control</sub>	Control input impedance	Internal pull down		50		kΩ
V <sub>status</sub>	Status output voltage range	Open drain, external pull up	0		5	V
V <sub>status_low</sub>	Status output low	I <sub>out</sub> = 1mA		0.5		V
V <sub>status_high</sub>	Status output high <sup>1)</sup>	I <sub>out</sub> = 1mA		DVDD		V
I <sub>status</sub>	Status output sink current		0		20	mA
Z <sub>status</sub>	Status output series impedance			240		
T <sub>heatsink</sub>	Heatsink temperature when Amplifier outputs start clipping and activates Clip signal CH1/CH2 outputs	2 x 100W		~90		°C
T <sub>heatsink</sub>	Heatsink temperature when Amplifier outputs start clipping and activates Clip signal CH1/CH2 outputs	2 x 75W		~93		°C
T <sub>heatsink</sub>	Heatsink temperature when Amplifier outputs start clipping and activates Clip signal CH1/CH2 outputs	2 x 65W		~94		°C

Table 15: Control and Status specifications

<sup>1)</sup>If pull-up resistor connected to DVDD

## 8.5 Timing

For detailed description of the below listed timing values, please consult Section 12 in this datasheet.

Symbol	Parameter	Conditions	Min	Typ	Max	Unit
t <sub>Supply-Audio-set</sub>	Time from all supplies <sup>1)</sup> are good to amplifier output starts switching	P <sub>o</sub> = 2 x 150W / 8 Ω		525		ms
t <sub>Supply-Audio-hold</sub>	Supply input – audio output hold time	P <sub>o</sub> = 2 x 19W / 8 Ω		106		ms
t <sub>Amp-Disable-set</sub>	Time from AmpDisable is pulled High (active) to amplifier output is disabled	P <sub>o</sub> = 2 x 0W / 8 Ω		555		ms
t <sub>Amp-Enable-release</sub>	Time from AmpDisable is pulled low (not active) to amplifier output is enabled	P <sub>o</sub> = 2 x 150W / 8 Ω		395		ms
t <sub>Amp-Protect-recovery</sub>	Amplifier Protect Recovery			9		s
t <sub>clip-out</sub>	Clip indication pulse duration			1		ms

Table 16: Timing specifications

<sup>1)</sup> VD/VS, VDD/VSS then Vdrive

## 9. Mechanical Specification

### 9.1 Dimensions

Symbol	Parameter	Condition	Min	Typ	Max	Unit
L	Module length			100		mm
W	Module width			60		mm
H	Module height				35	mm
Mass	Weight			133		g
H	Mounting hole depth Heatsink	M3 threads on heatsink		4.0	20	mm
T	Mounting torque	M3 threads on mounting base plate		0.5		Nm

Table 17: Mechanical dimensions

### 9.2 3D-View

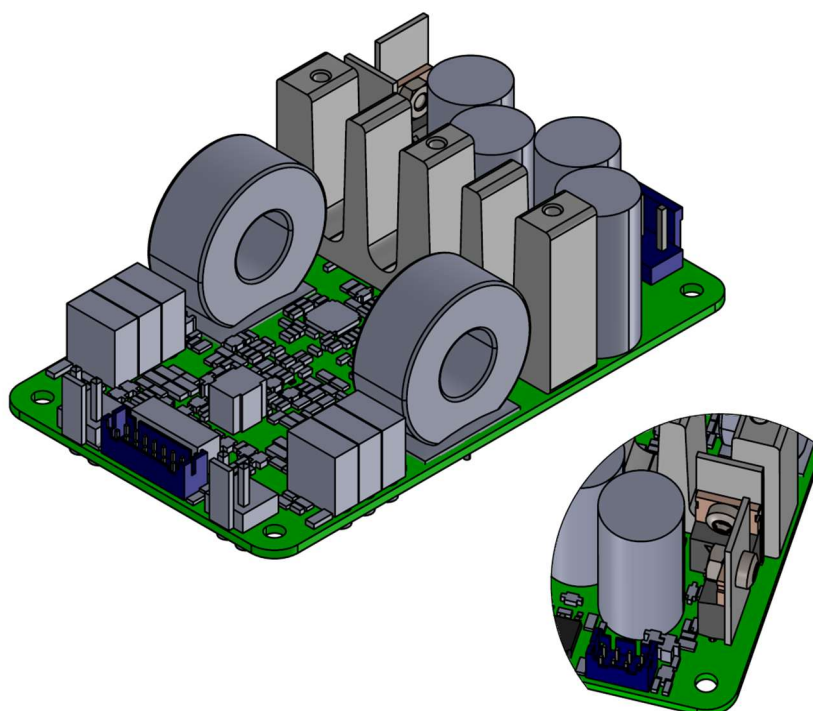

Figure 3: ICEpower300A2 D3-View

## 9.3 Mounting holes

The ICEpower300A2 module is designed for flexible mounting either on bottom side spacers or by the top side heatsink for easy mechanical interface to external heatsink for even higher continuous power capability.

When choosing screws for mounting, the depth of the threaded holes must be observed as well as the specified mounting torque, both specified in Section 9.1

### 9.3.1 Mounting on bottom side Spacers

The module is mounted by means of 3.5 mm holes in the board. The holes are indicated in Figure 4

12 mm spacers are recommended for mounting on the bottom side in order to ensure good ventilation around the module. To ensure proper safety a clearance of 8mm between module and chassis is necessary.

Drill Pattern (all dimensions are in mm):

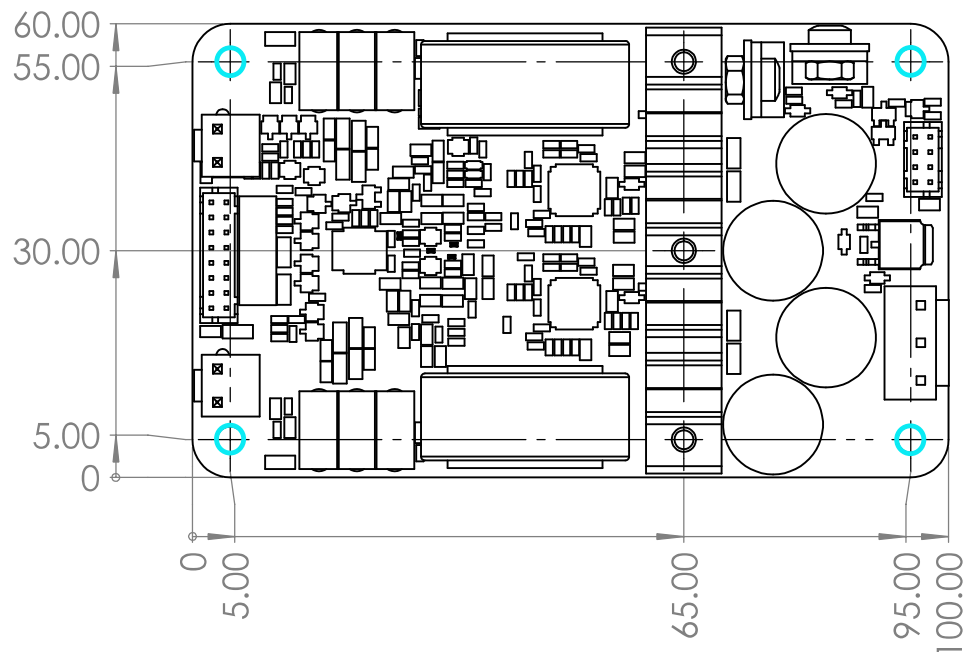

Figure 4: ICEpower300A2 Top view bottom side spacers mounting holes.

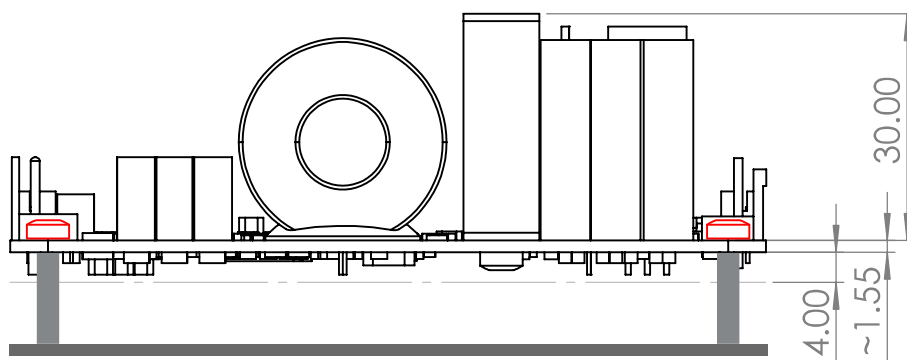

Figure 5: ICEpower300A2 Side view bottom side spacers mounting example with 12 mm spacers.

### 9.3.2 Mounting on top side Heatsink

The module should not be mounted solely by the top side heatsink. Use 30 mm spacers for support in the positions marked in Figure 6 with cyan circles. Use bolts for support in the positions marked with cyan squares. Electrically conductive spacers must be used to comply with the EMC regulations.

Remember to ensure good airflow and ventilation above the ICEpower300A2 module.

Finally, thermal conductive compound can be used in the mechanical interface between top side heatsink and additional chassis/heatsink if required. Please follow the instructions provided by the thermal compound manufacturer as incorrect use can result in non-optimal performance.

#### Drill Pattern:

All dimensions are in mm.

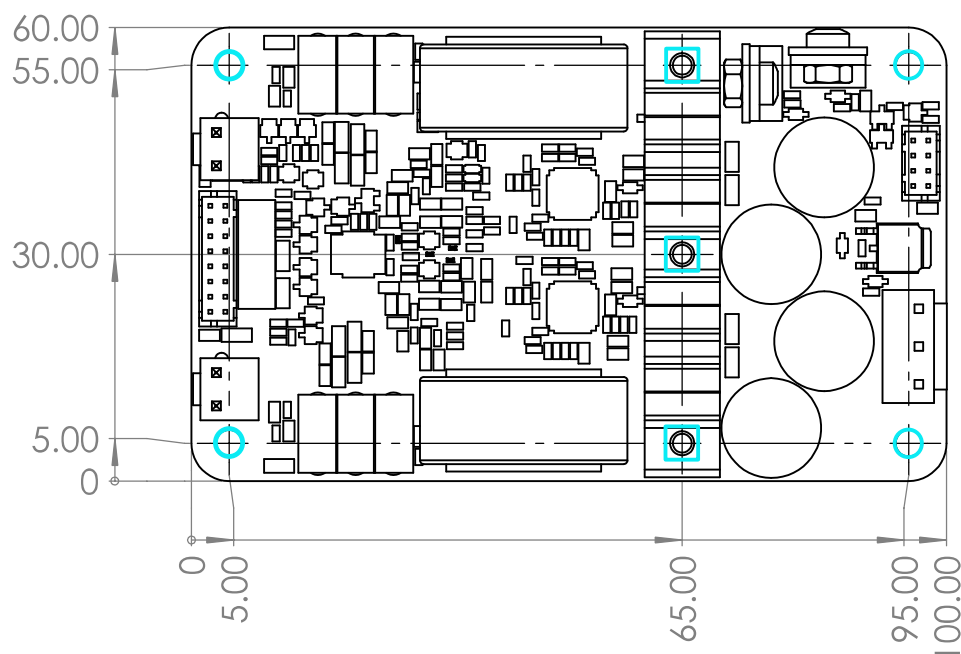

Figure 6: ICEpower300A2 Top view Heatsink mounting holes.

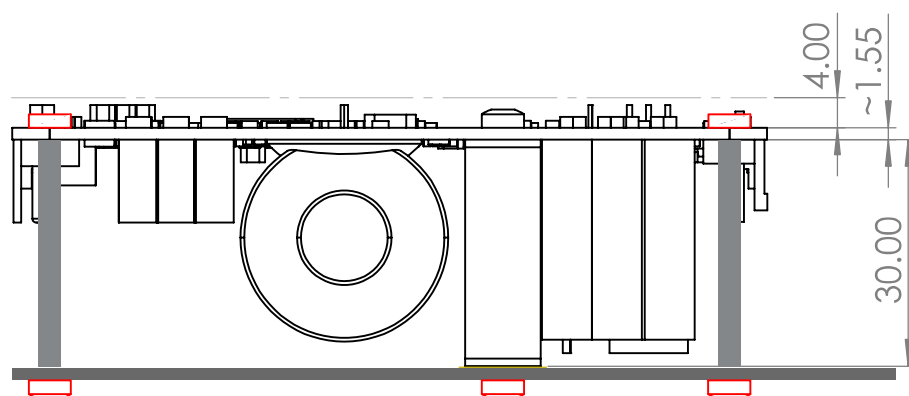

Figure 7: ICEpower300A2 Side view Heatsink mounting example with 30 mm spacers.



## 9.4 Environmental Specifications

Symbol	Parameter	Conditions	Min	Typ	Max	Units
T <sub>operating</sub>	Ambient temperature, operating	End-customer use cases	-10		55 <sup>1)</sup>	°C
T <sub>storage</sub>	Ambient temperature, storage	End-customer use cases	-40		70	°C
T <sub>shelf</sub>	Ambient temperature, shelf	Storage before goods sold to end-customer	0		60	°C
RH	Relative humidity	Non-condensing Operating and storage			85	%
	Altitude, operating				2000	m

Table 18: Environment specifications

<sup>1)</sup>For safety test at 55 °C ambient with 1/8 power, the module might require additional cooling in terms of forced air with a fan or a larger heatsink.

## 10. Typical Performance Characteristics SE

Unless otherwise specified:

- One channel driven, all channels enabled.
- $f = 1 \text{ kHz}$ ,  $T_a = 25 \text{ }^\circ\text{C}$ ,  $R_L = 4\Omega$ ,  $V_D/V_S = \pm 57\text{V}$ ,  $V_{DD}/V_{SS} = \pm 12\text{V}$ ,  $V_{drive} = V_S + 12\text{V}$ .
- Audio Precision AUX0025 passive class-D filter and AES17 20 kHz 7<sup>th</sup> order measurement filter.
- ICEpower300A2 mounted on standoffs horizontal on plain surface, no additional heatsink or fan.

### 10.1 Frequency Response

Conditions: Measurement bandwidth 500 kHz,  $V_o = 2\text{V}_{rms}$  (1Wrms@4Ω)

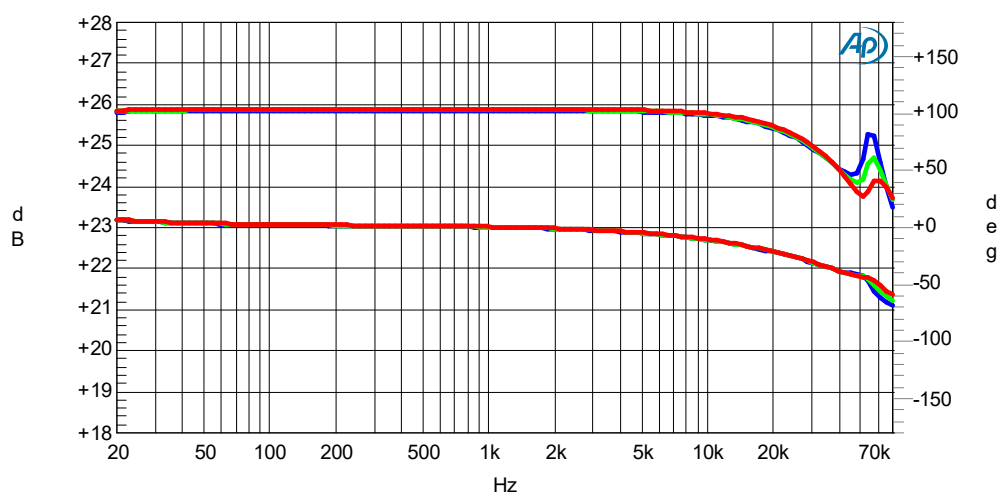

Figure 8: Frequency response in 4 Ω (blue), 8 Ω (green) and open load (red). Top – amplitude. Bottom – phase

## 10.2 Total Harmonic Distortion + Noise

Conditions: The frequency 6.67 kHz corresponds to the worst-case scenario where both 2<sup>nd</sup> and 3<sup>rd</sup> harmonics are within the audio band. 100Hz (blue), 1kHz (green) and 6.67kHz (red).

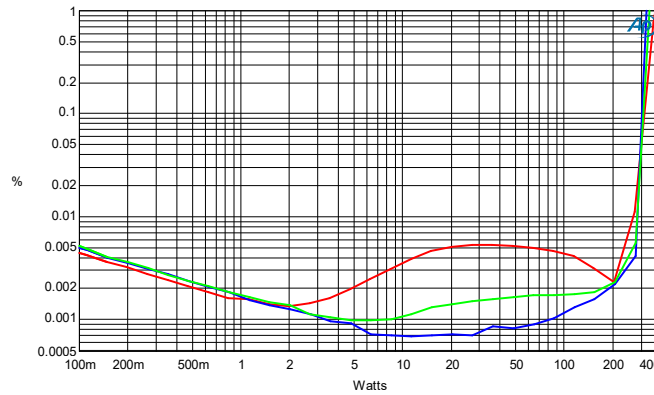

Figure 9: THD+N vs. Po @ 100Hz, 1kHz, 6.67kHz, RL=4Ω

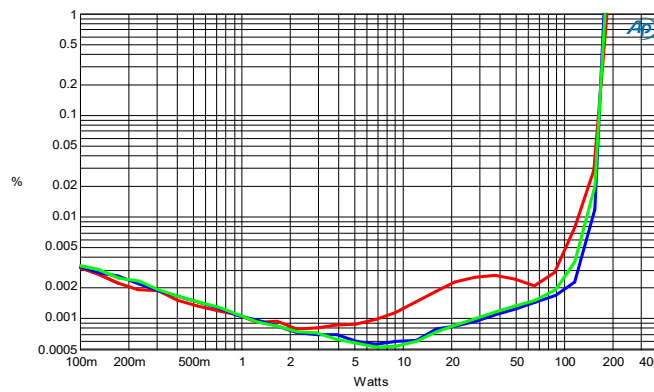

Figure 10: THD+N vs. Po @ 100Hz, 1kHz, 6.67kHz, RL=8Ω

## 10.3 Idle Noise

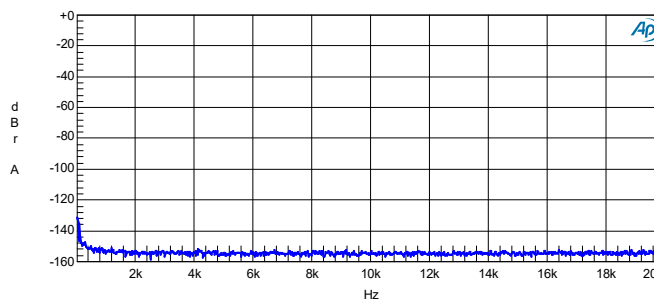

Figure 11: Idle noise (64K FFT), RL = 4 Ω (Relative to 300 W)

## 10.4 Intermodulation Distortion

Conditions: The selected CCIF signal is equal amplitude 18 kHz and 19 kHz. The difference tone at 1 kHz is detected. Dual tone intermodulation spectrum, 0 – 20 kHz @ 0 dB = 300 W / 4 Ω

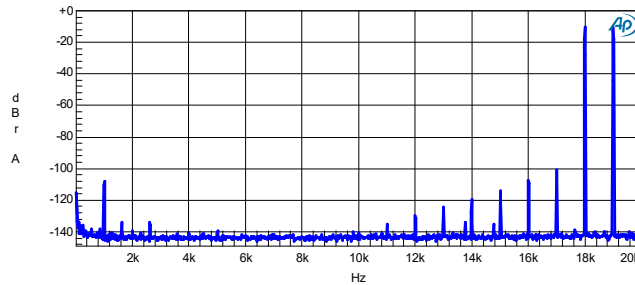

Figure 12: CCIF vs.  $P_0$ ,  $R_L=4 \Omega$ ,  $f_1=18 \text{ kHz}$ ,  $f_2=19 \text{ kHz}$

## 10.5 Crosstalk

Conditions:  $P_0=37.5 \text{ W}$ ,  $R_L=4 \Omega$  and wide bandwidth measurement.

Both channels active/enabled during all measurements, only input signal is switched.

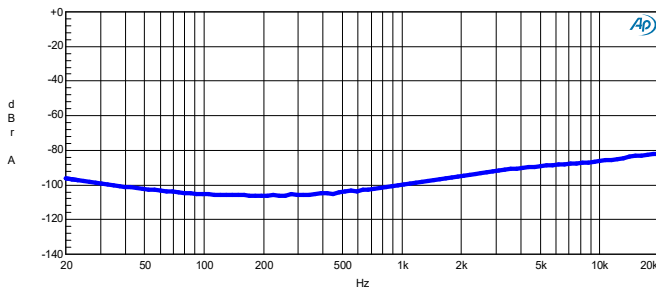

Figure 13: Cross talk, Ch1 vs Ch2.  $1/8 P_{max} = 37.5 \text{ W @ } 4 \Omega$

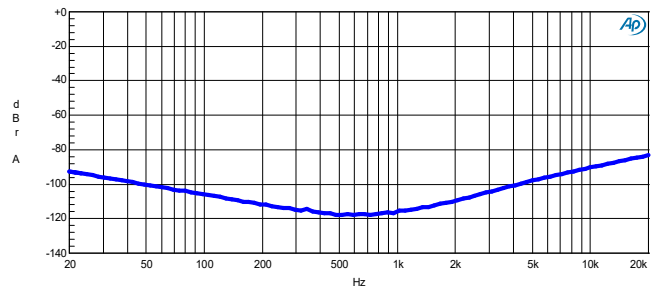

Figure 14: Cross talk, Ch2 vs Ch1.  $1/8 P_{max} = 37.5 \text{ W @ } 4 \Omega$

## 10.6 Output Impedance

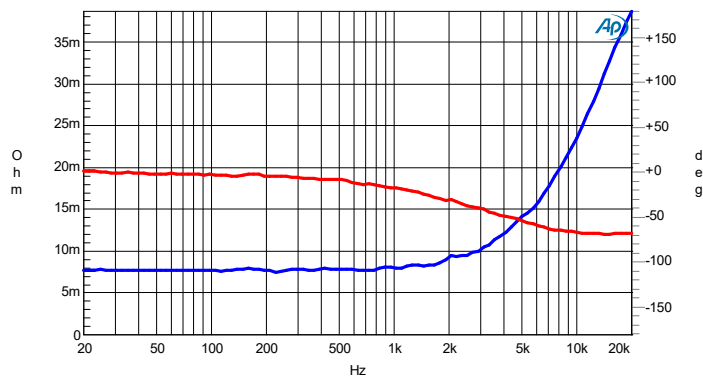

Figure 15: Output Impedance Amplitude (Blue), and Phase (Red)

## 10.7 Damping Factor

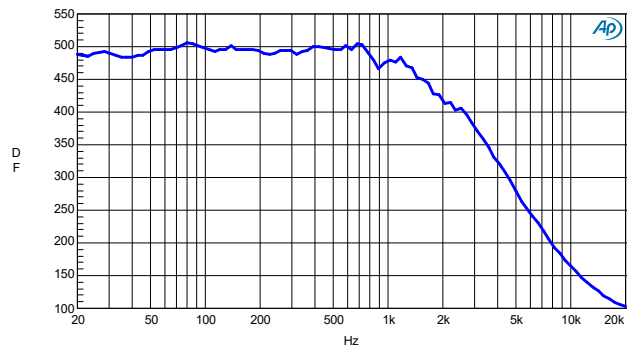

Figure 16: Damping factor in 4 Ω

## 10.8 Output Power vs. Rail Voltage supplies

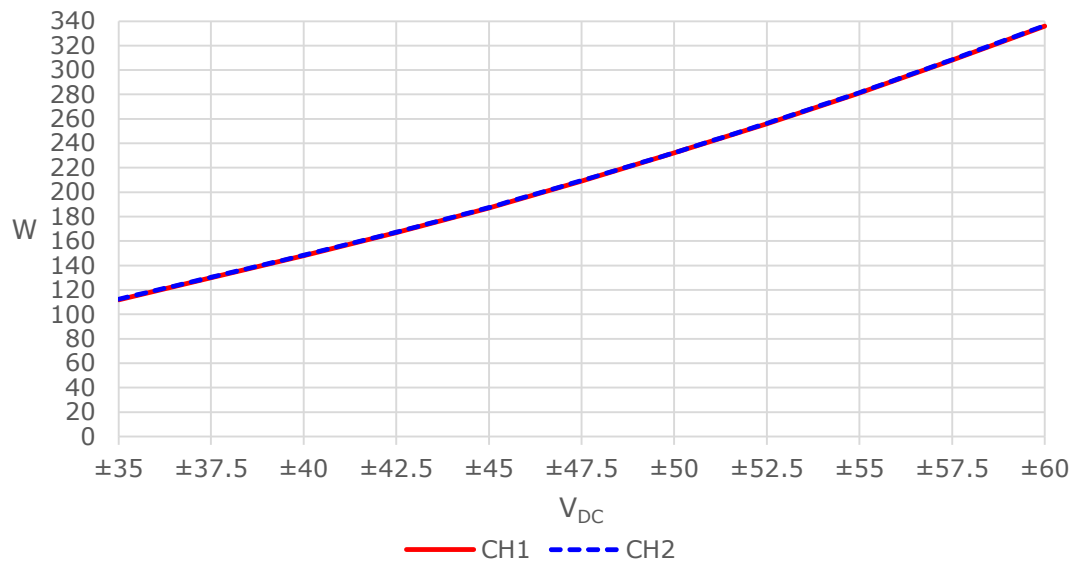

Figure 17: Output power @ 4 Ω and 1 % THD+N vs. rail Voltage, 2 ch driven, CH1 (red) CH2 (blue-dashed), 1kHz

## 10.9 Power Efficiency

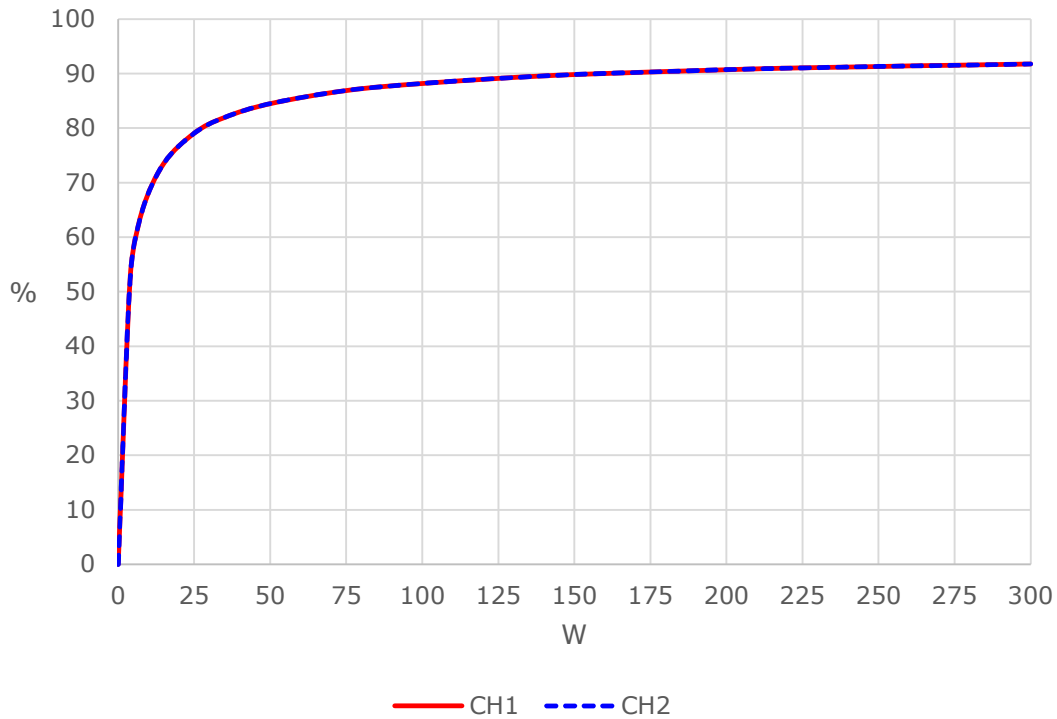

Figure 18: Power efficiency vs. output power per channel @ 4 Ω, 2 ch driven, CH1 (red) CH2 (blue-dashed)

## 10.10 Dissipated Power

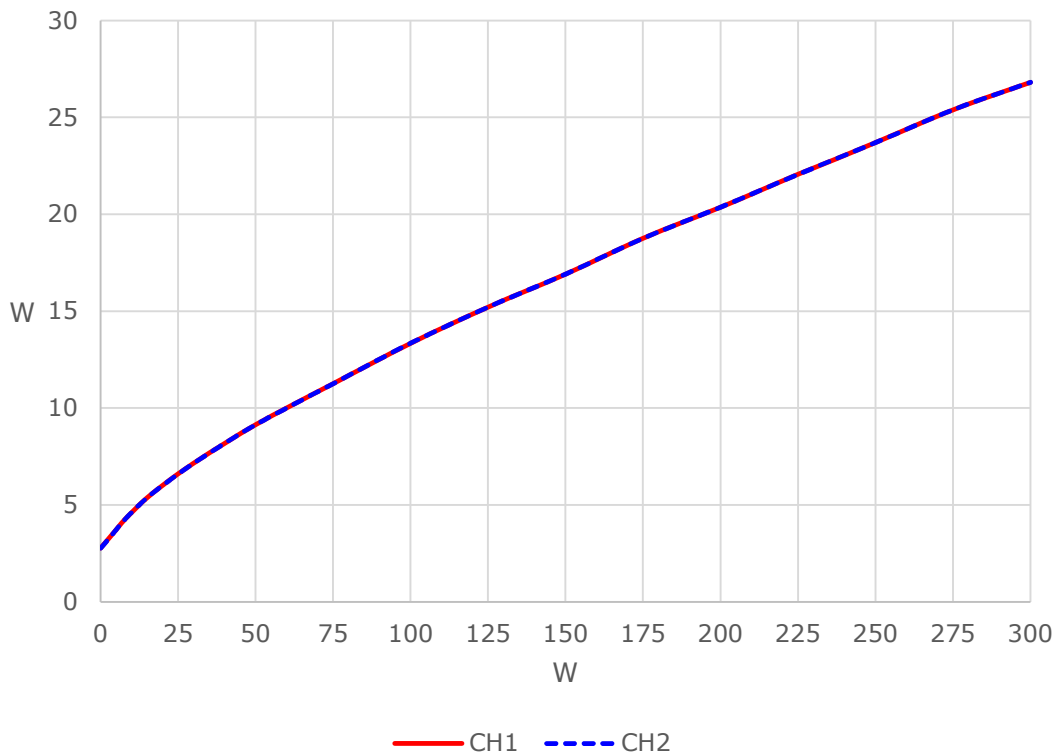

Figure 19: Dissipated power per channel vs. output power per channel @ 4 Ω, 2 CH driven, CH1 (red) CH2 (blue-dashed)

# 11. Typical Performance Characteristics BTL

Unless otherwise specified:

- One channel driven, all channels enabled.
- $f = 1 \text{ kHz}$ ,  $T_a = 25 \text{ }^\circ\text{C}$ ,  $R_L = 8\Omega$ ,  $V_D/V_S = \pm 57\text{V}$ ,  $V_{DD}/V_{SS} = \pm 12\text{V}$ ,  $V_{drive} = V_S + 12$ .
- Audio Precision AUX0025 passive class-D filter and AES17 20 kHz 7<sup>th</sup> order measurement filter.
- ICEpower300A2 mounted on standoffs horizontal on plain surface, no additional heatsink or fan.

## 11.1 Frequency Response

Conditions: Measurement bandwidth 500 kHz,  $V_o = 2.83\text{V}_{rms}$  ( $1\text{W}_{rms}@8\Omega$ )

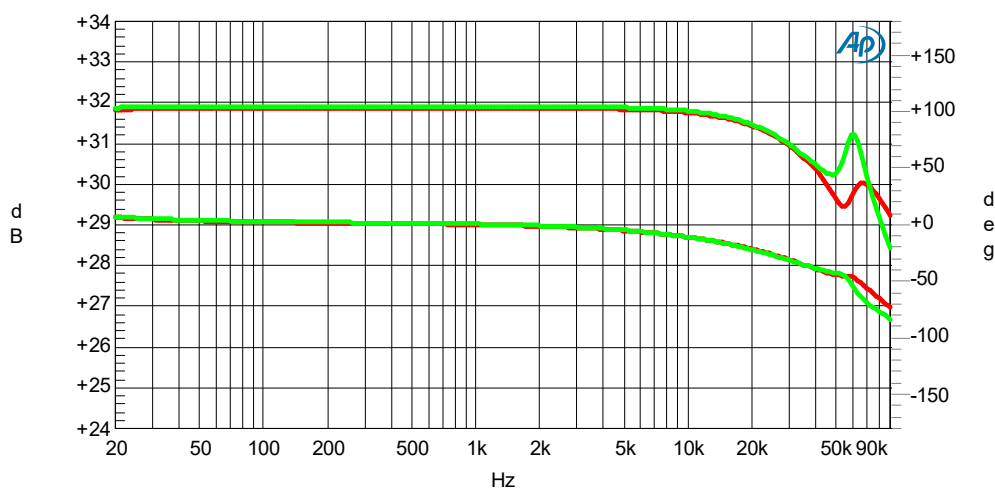

Figure 20: Frequency response in 8  $\Omega$  (green) and open load (red). Top – amplitude. Bottom – phase

## 11.2 Total Harmonic Distortion + Noise

Conditions: The frequency 6.67 kHz corresponds to the worst-case scenario where both 2<sup>nd</sup> and 3<sup>rd</sup> harmonics are within the audio band. 100Hz (blue), 1kHz (green) and 6.67kHz (red).

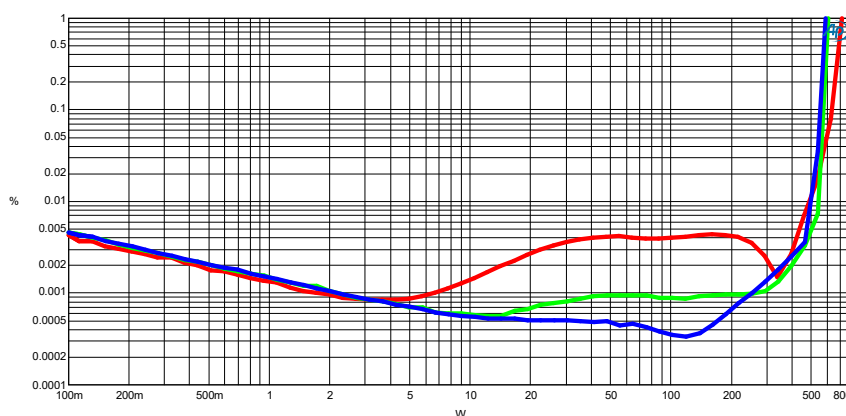

Figure 21: THD+N vs.  $P_o$  @ 100Hz, 1kHz, 6.67kHz,  $R_L = 8\Omega$

### 11.3 Idle Noise and Low Power spectrum

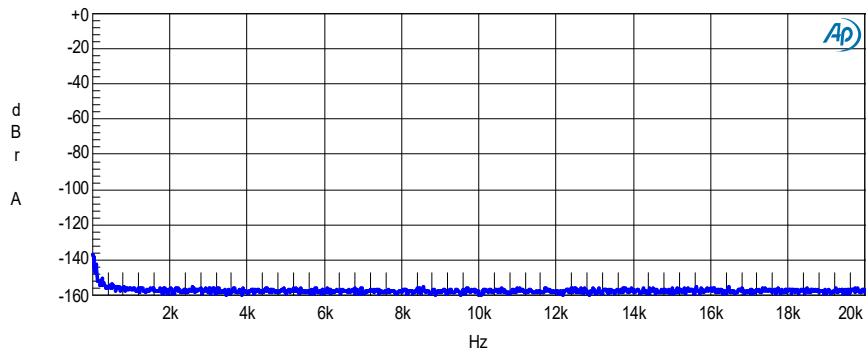

Figure 22: Idle noise (64K FFT).  $R_L = 8 \Omega$  (Relative to 600 W into  $8 \Omega$ )

### 11.4 Intermodulation Distortion

Conditions: The selected CCIF signal is equal amplitude 18 kHz and 19 kHz. The difference tone at 1 kHz is detected. Dual tone intermodulation spectrum, 0 – 20 kHz @ 0 dB = 600 W /  $8 \Omega$

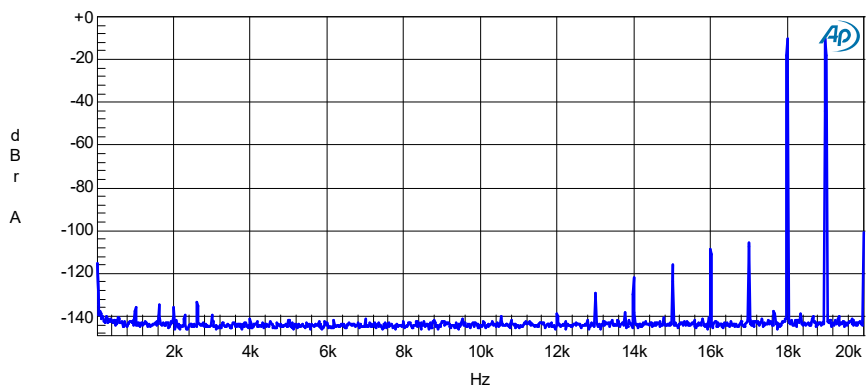

Figure 23: CCIF vs.  $P_0$ ,  $R_L=8 \Omega$ ,  $f_1=18 \text{ kHz}$ ,  $f_2=19 \text{ kHz}$



## 11.5 Output Impedance

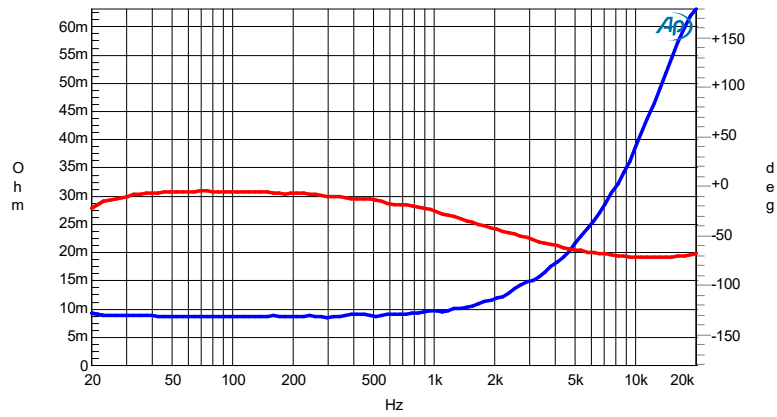

Figure 24: Output Impedance BTL (Blue), and Phase (Red)

## 11.6 Damping Factor

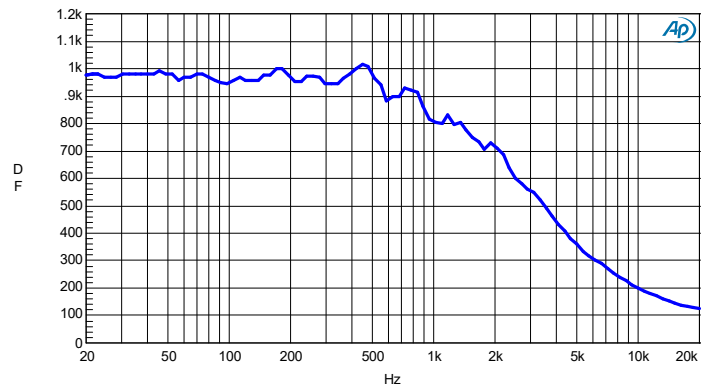

Figure 25: Damping factor in 8  $\Omega$

## 12. Functional Description

ICEpower300A2 will start operating when power is applied to the module and therefore no special control is needed for simple applications. For more advanced applications, a wide set of control, status and monitoring inputs and outputs are available all through a connector following the ICEpower standard interface definition.

Following ICEpower's "Music at All Times" philosophy, the module will operate under all conditions except for potentially destructive situations. At power-up, the 300A2 module performs comprehensive checks to verify operation conditions and to check for errors. If an error is detected, the module will try to reboot after a short delay. As part of the effort to keep music playing, the module monitors numerous internal parameters during operation and reacts proactively if required.

In three distinct situations, the module will initiate a progressive clipping of the audio signal to limit the loading of the module. These situations are:

- Temperature conditions close to thermal shutdown
- Excess super-sonic audio content
- Over current

Should the progressive limitation of the output power be insufficient to maintain safe operation or if a potentially destructive error should occur, the 300A2 module will shut down and automatically restart after the overload situation is removed.

In the following subsections, a description is given for all ICEpower300A2 features organized by the connector in which the corresponding input or output is located.

### 12.1 Audio Input

The audio inputs of the 300A2 are high impedance fully differential audio input including a non-inverting signal input, inverting signal input and a shield ground reference.

The audio inputs can be used in both a semi-balanced input configuration and in a fully balanced configuration. In semi-balanced configuration, it is recommended to connect the non-inverting input to a single ended signal source and use the inverting input as ground sense on the signal source ground reference. In both semi-balanced and in fully balanced configuration, the signal ground should be connected to ground on the front-end PCB.

To prevent ground loop related noise and hum problems, the signal ground is fitted with low value series resistors on the module i.e., the signal ground wire must not carry any additional current. The recommended connection to the audio input is shown on Figure 33 in Section 13.

The two audio signal inputs share the same connector on the 300A2 module.

### 12.2 Loudspeaker Outputs

The loudspeaker output of the 300A2 is an unbalanced output capable of driving complex speaker loads.

The loudspeaker output is fully overload and short circuit protected. In case of an overload or short circuit event, the module will shut down and resume operation when the overload or short circuit has been removed.

The loudspeaker output is in an unbalanced configuration, bridging of the two channels is possible.

## 12.3 Power Supply Input

All power lines should be connected before powering the ICEpower300A2. First VD/VS and VDD/VSS then Vdrive. After all power supplies are applied to the 300A2, the module will read the control inputs and start operating accordingly. If the module controls are left unconnected, the module will start normal operation without further action.

Important: The module should only be supplied by either DVDD/DVSS or VDD/VSS.

The power up and power down timing is shown in Figure 26 and specific timing values are available in Section 8.5

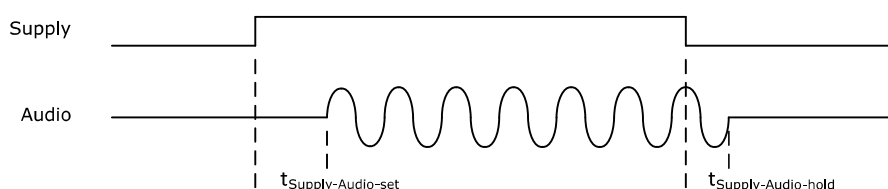

Figure 26: Power up timing after all supplies (VD, VS, and all aux supplies) are good to amplifier starts switching

## 12.4 Basic Control and Status

The Basic Control connector and Auxiliary Supply connector for e.g., a signal front-end PCB and the following features:

- AmpDisable
- BTLselect
- ReduceClip+
- Vmon1 and Vmon2
- Protect
- Clip1 and Clip2
- Pullupto5V
- DCerror

The recommended connection to the control input and status outputs are shown on Figure 35 and Figure 36 in Section 13.

### 12.4.1 AmpDisable Input

The AmpDisable input shuts down the ICEpower300A2 amplifier section when pulled high. An internal pull down ensures normal operation if the AmpDisable input is left unconnected.

This feature can be used in e.g., applications where a front-end needs time to boot a DSP based system at power up before enabling the amplifier.

Timing of the AmpDisable inputs shown in Figure 27 and specific timing values are available in Section 8.5.

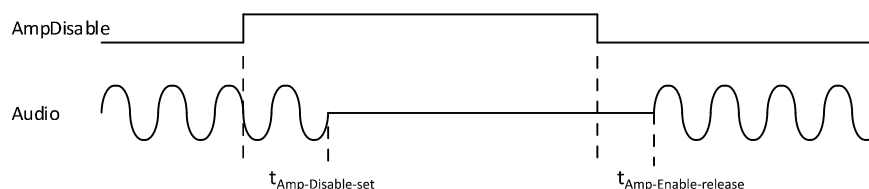

Figure 27: Standby and AmpDisable timing

Advanced pop and click reduction mechanisms are built into the 300A2 leaving almost no audible artifacts when the AmpDisable input is used.

### 12.4.2 BTLselect input

The BTL mode synchronizes the two SE channels to avoid idle tones and to improve the performance when driving the two channels in BTL. To enable the BTL mode the BTLselect, pin 8 on connector P7, needs to be pulled high. In BTL mode invert the polarity of channel 2 relative to channel 1, as illustrated in Figure 28.

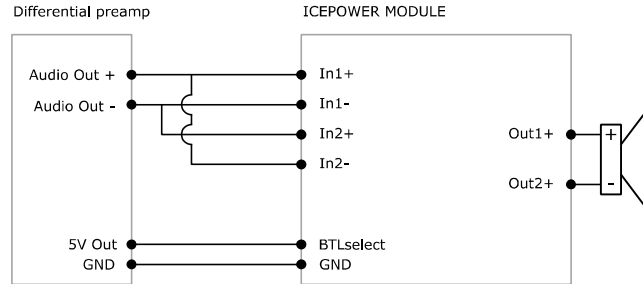

Figure 28: ICEpower300A2 BTL block diagram

The BTL output is taken between the two positive outputs, this means pin 1 on connector P4 and P5. Figure 29 indicates pins related to BTL functionality.

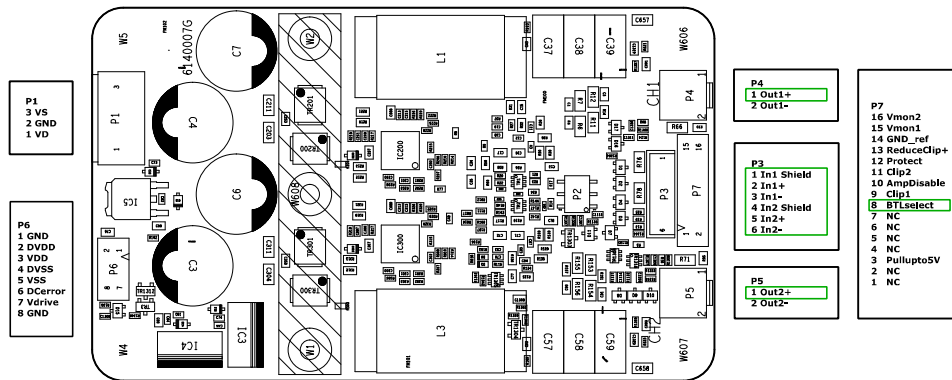

Figure 29: ICEpower300A2 connector overview in BTL mode<sup>1)</sup>

<sup>1)</sup>Pull up to 5V can be used to enable BTL select, for simple testing or permanent BTL configuration.

### 12.4.3 Reduce Clip+ input

The Reduce Clip+ input is an analog DC input used to reduce the clip level of the input buffer.

Can be used to send an analog signal to reduce the clipping level, this can reduce the maximum output power if the supply gets hot.

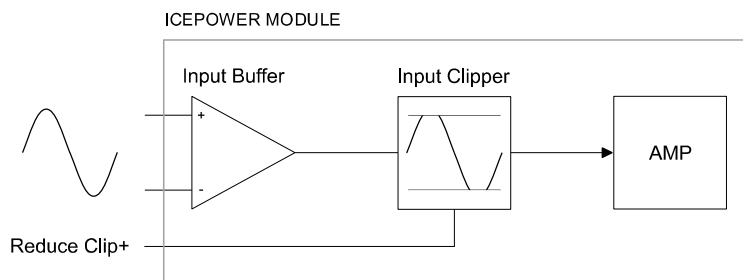

Figure 30: Clip reduce block diagram.

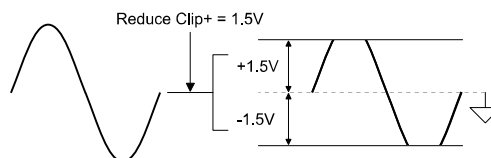

Figure 31: Example of Reduce Clip set to 1.5V

#### 12.4.4 Vmon1 and Vmon2 output

Analog voltage divider high impedance output

Analog voltage divider connected to the output of the power stage. This serves as a high impedance output to monitor the output voltage.

#### 12.4.5 Protect output

In case of potentially destructive overload situations, the 300A2 will shut down and resume operation after a short delay or after the overload-condition has been removed. These events are reported by a low level on the Protect output.

Events that will trigger the Protect output are:

- Severe amplifier overcurrent conditions and short circuit in the amplifier section.
- Over-temperature errors in the module.
- DC error
- Supply voltages are out of normal operating conditions
- Excess sub-sonic or super-sonic audio content

In the first two cases, the 300A2 module will resume operation shortly after the error condition has been removed. For the over-temperature case, it is also required that the module temperature is brought below the temperature reset threshold.

The Protect output is an open-drain output pulled high by external pull-up resistors. Interface schematics can be found in Section 13.3

Timing of the protection events are shown in Figure 32 and specific timing values are available in Section 8.5.

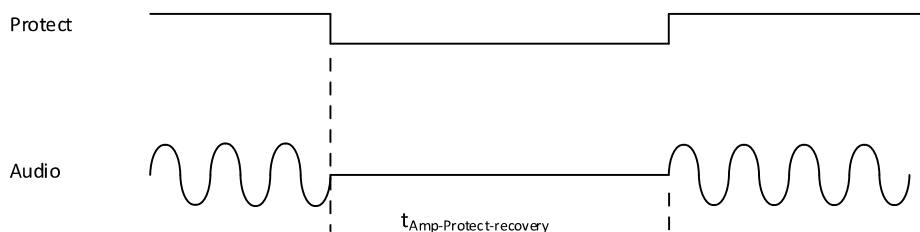

Figure 32: Amplifier Protect recovery

#### 12.4.6 Clip1 and Clip2 output

The Clip output is a multi-purpose output indicating:

- Audio signal voltage clipping

The Clip1 and Clip2 outputs are audio signal clipping indicators, one per channel. Clipping is indicated by a low on the Clip1 and Clip2 for channel 1 and 2 respectively. The clipping outputs stays low for the full duration of clipping in the audio signal, but to make it easier to detect very short clipping event and in cases where the clip signals are directly connected to a LED, the clipping signals on Clip1 and Clip2 have a minimum duration  $t_{\text{Clip-out}}$ .

The Clip output is an open drain output pulled high by external pull-up resistors. Interface schematics can be found in Section 13.3

#### 12.4.7 Pullupto5V output

Used exclusively for BTL select and LED output identification.

#### 12.4.8 DCerror output

The DC Error is an output indicating DC on the output. The module will shut down and send a shutdown signal to the power supply.

The DC Error output is an open drain output pulled high by external pull-up resistors. Interface schematics can be found in Section 13.3

# 13. Interface Schematics

In the following sub-sections, proposed interface schematics are shown. These schematics should be considered an assistance to the design process, and they represent the recommended interface to the 300A2 module.

## 13.1 Audio Input

Generic interface for fully differential use of analog inputs.

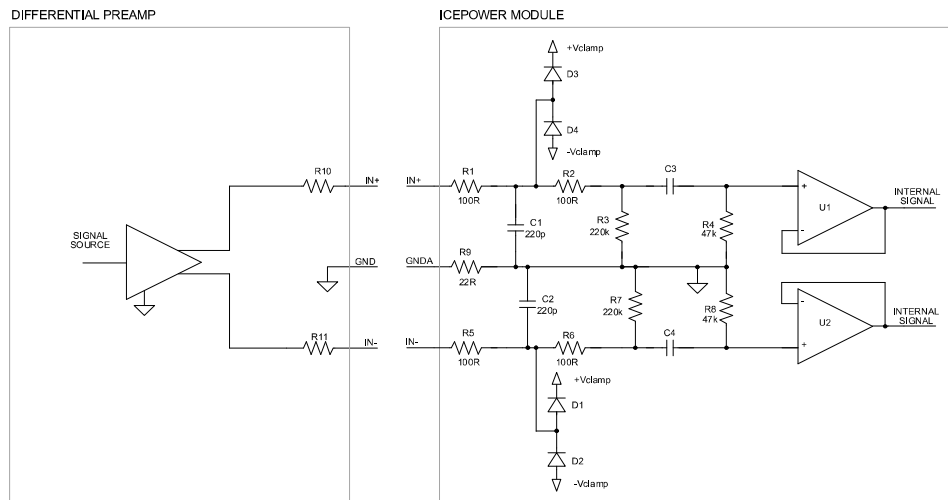

Figure 33: Fully balanced audio input interface schematics

Generic interface for semi-balanced use of the analog input.

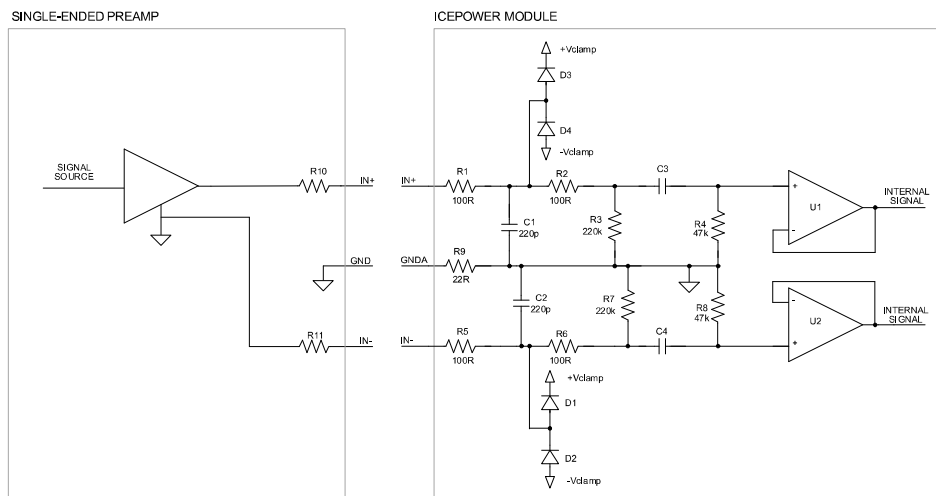

Figure 34: Semi-balanced audio input interface schematics

## 13.2 Control Input

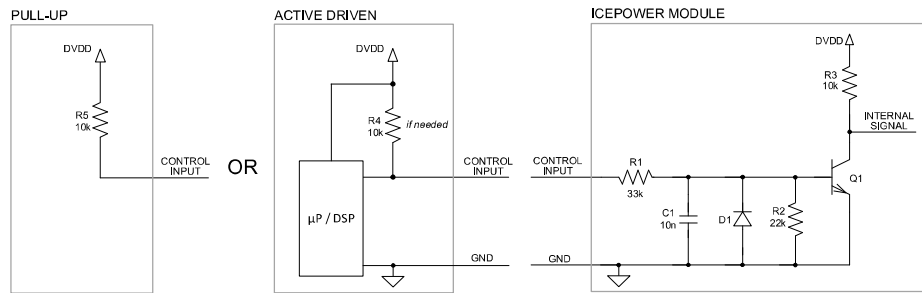

Figure 35: Recommended control input interface schematics DVDD<sup>1)</sup>

<sup>1)</sup>External DVDD for PULL-UP can be selected from 5V to 20V

## 13.3 Status Output

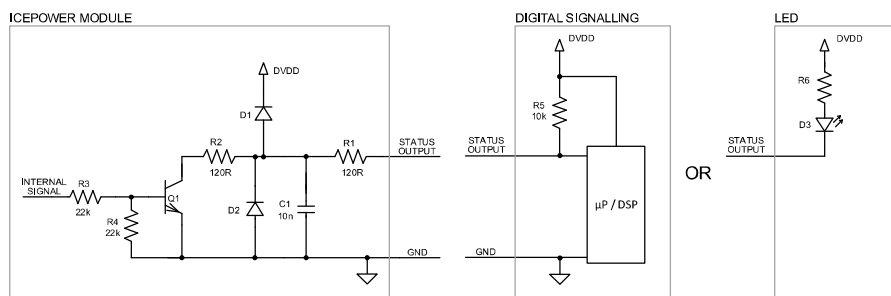

Figure 36: Recommended status output interface schematics

## 14. Integration Guidelines

The 300A2 module is designed with ease of integration in mind. This includes both electrical, EMC, thermal and mechanical integration. In the following sub-sections, recommendations will be given to assist the end-product design process.

### 14.1 Grounding Scheme

Depending on the complexity of the end-product several grounding schemes can be used. On Figure 37: Grounding scheme an example of the grounding scheme usable on the 300A2 module is shown for a simple setup including a front-end PCB and PSU.

The low value series resistor included in the signal shield connection prevents ground loops between the 300A2 module and the front-end PCB. To prevent similar ground loops between the PCBs and the chassis, it is recommended not to connect the audio input connector to the chassis but to have them grounded on the front-end PCB.

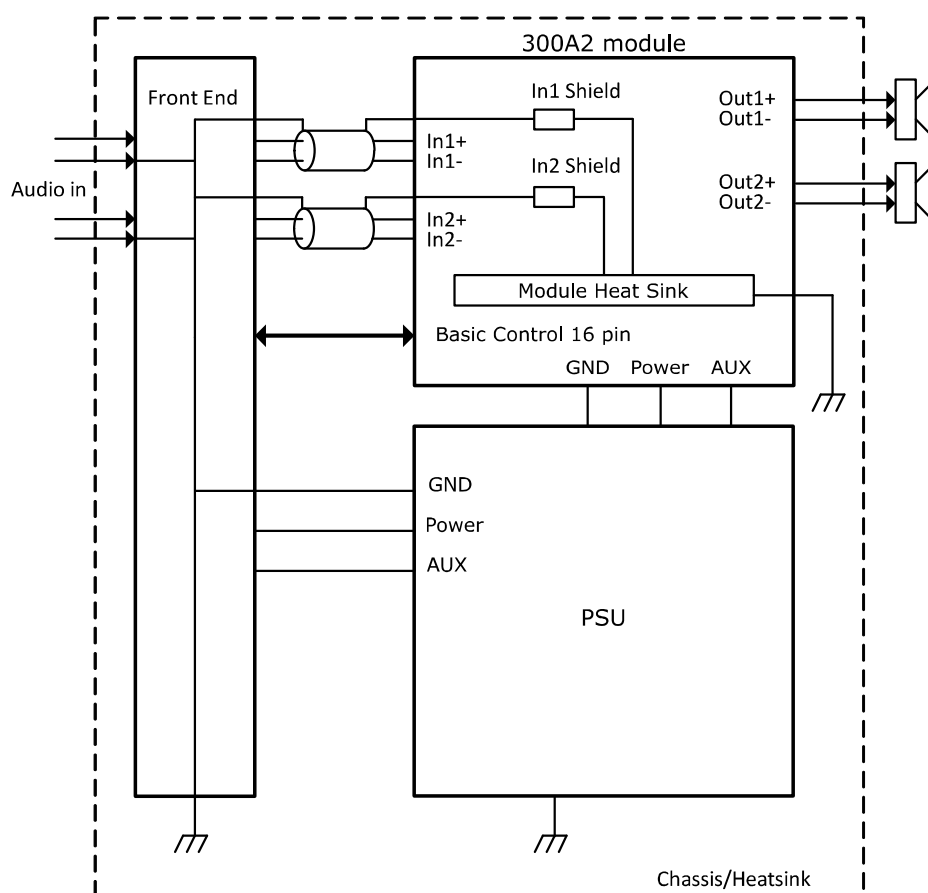

Figure 37: Grounding scheme



## 14.2 EMC Management

As described in Section 1, the ICEpower300A2 module is EMC pre-approved as is when mounted on a standard aluminum open back plate. However, because of the high-power switching electronics included in the module, some EMC precautions are required to ensure an EMC approvable end-product design.

- Connect the module mounting holes to the chassis as described in section 9.3. Mounting of the module isolated from the chassis may cause increased HF radiation.

Do not use cable/wires between module and other PCBs that are longer than necessary. Avoid wire loops on the speaker output wires. Use wires closely paired side by side or if required use twisted or shielded cables.

- Do not route cables near magnetic components on the module e.g. inductors and transformers.
- Do not bundle amplifier DC rail supply wires together with other cables.
- Do not bundle speaker wires together with other cables (Figure 39).

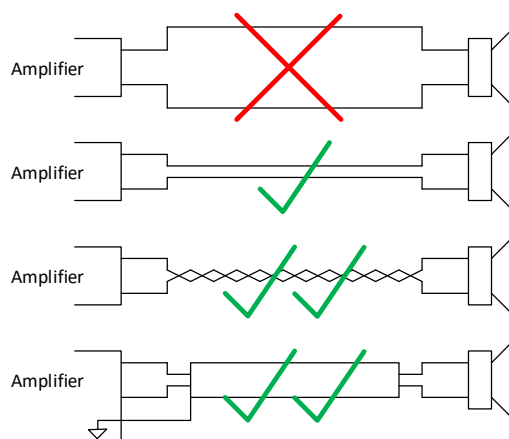

Figure 38: Speaker wire routing

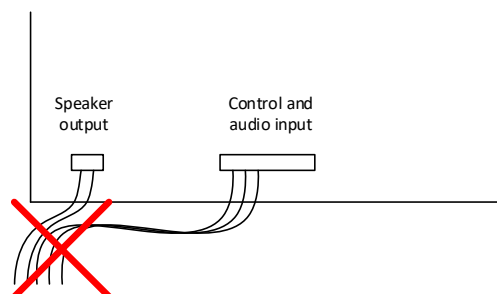

Figure 39: Wire bundling

Depending on the end-product application, additional EMC initiatives and filtering may be required to have the entire product EMC approved. The reason for this could be, among others, insufficient cable routing within the application or DSP/microprocessor based front-end systems.

To improve on EMC performance, it is often advisable to revisit the used grounding scheme and cable routing and add EMC filters on some or all the connectors on the end-product.

## 15. Safety and EMC Standards

ICEpower300A2 is design to comply with EMC directives and safety standards.

## 16. ESD Warning

ICEpower products are manufactured according to the following ESD precautions:

ANSI/ESD-S20.20-2014: Protection of Electrical and Electronic Parts, Assemblies and Equipment.

Further handling of the products should comply with the same standard.

The general warranty policy of ICEpower a/s does not cover ESD damaged products due to improper handling.

## 17. Ordering, Packaging and Storage

All ICEpower modules are packaged in ESD safe bubble wrap bags and cardboard boxes.

### 17.1 Ordering Information

Order Codes	Description	Part Number
ICEpower300A2	Two channel 300 W ICEpower amplifier	8008207

### 17.2 Shipping Dimensions and Weight

Package	Quantity	Dimensions (w × d × h) [mm]	Gross Weight [kg]
Carton	24	390 × 290 × 230	4.3

### 17.3 Storage Conditions

Storage Humidity and Temperature:

Please find storage humidity and temperature information in Section 8.3, Environmental Specifications.

#### Stacking

A maximum of 4 cartons must be stacked on top of each other.

Pallets may not be stacked on top of each other.

## 18. Legal Notes

ICEpower a/s believes that the information in this datasheet is accurate and reliable. However, it is provided "as is" without any warranties of any kind. ICEpower a/s and its suppliers, to the fullest extent permitted by law, disclaim all warranties, including the warranty of merchantability, warranty of non-infringement of third-party rights, and the warranty of fitness for a particular purpose. ICEpower a/s and its suppliers make no warranties about the accuracy, reliability, completeness, or timeliness of the material, services, software, text, graphics and links. In no event will ICEpower a/s be liable to any party for any damages whether direct, indirect, special, consequential or other for any use or inability to use of this datasheet, including, without limitation, any damages for lost profits, business interruption, loss of programs or other data on your information handling system or otherwise, even if we are expressly advised of the possibility of such damages.

Information in this datasheet may contain technical inaccuracies or typographical errors. The information in the datasheet may be changed at any time without prior notice or obligation.

ICEpower® is a trademark of ICEpower a/s.

ICEpower a/s products are not authorized for use as critical components in life support devices or life support systems without the express written approval of the president and general counsel of ICEpower a/s. As used herein:

Life support devices or systems are devices or systems which, (a) are intended for surgical implant into the body, or (b) support or sustain life, and whose failure to perform when properly used in accordance with instructions for use provided in the labelling, can be reasonably expected to result in a significant injury to the user.

A critical component is any component of a life support device or system whose failure to perform can be reasonably expected to cause the failure of the life support device or system, or to affect its safety or effectiveness.

## 19. Contact

For additional information about the ICEpower® technology from ICEpower a/s, visit our web site or contact us.

ICEpower a/s  
Vandtårnsvej 62A, 3<sup>rd</sup> floor, B  
DK-2860 Søborg  
Denmark

[www.icepower.dk](http://www.icepower.dk)  
[info@icepower.dk](mailto:info@icepower.dk)

ICEpower a/s ©2020